



5500



**HPA**

**Faip**



Sollevatore elettroidraulico  
a due colonne con bracci  
simmetrici ribassati a 4 stadi  
*Electro-hydraulic two-post lift  
with 4-section low profile lifting arms*

Elevador electro-hidráulico de dos  
columnas con brazos de 4 etapas

**P2C 255 HTS-XV**

## P2C 255 HTS-XV

Dedicato ai Centri di Veicoli Industriali e Commerciali.  
*Dedicated to Industrial and Commercial Vehicle Centers.*  
Dedicado a los Centros de Vehículos Industriales y Comerciales.

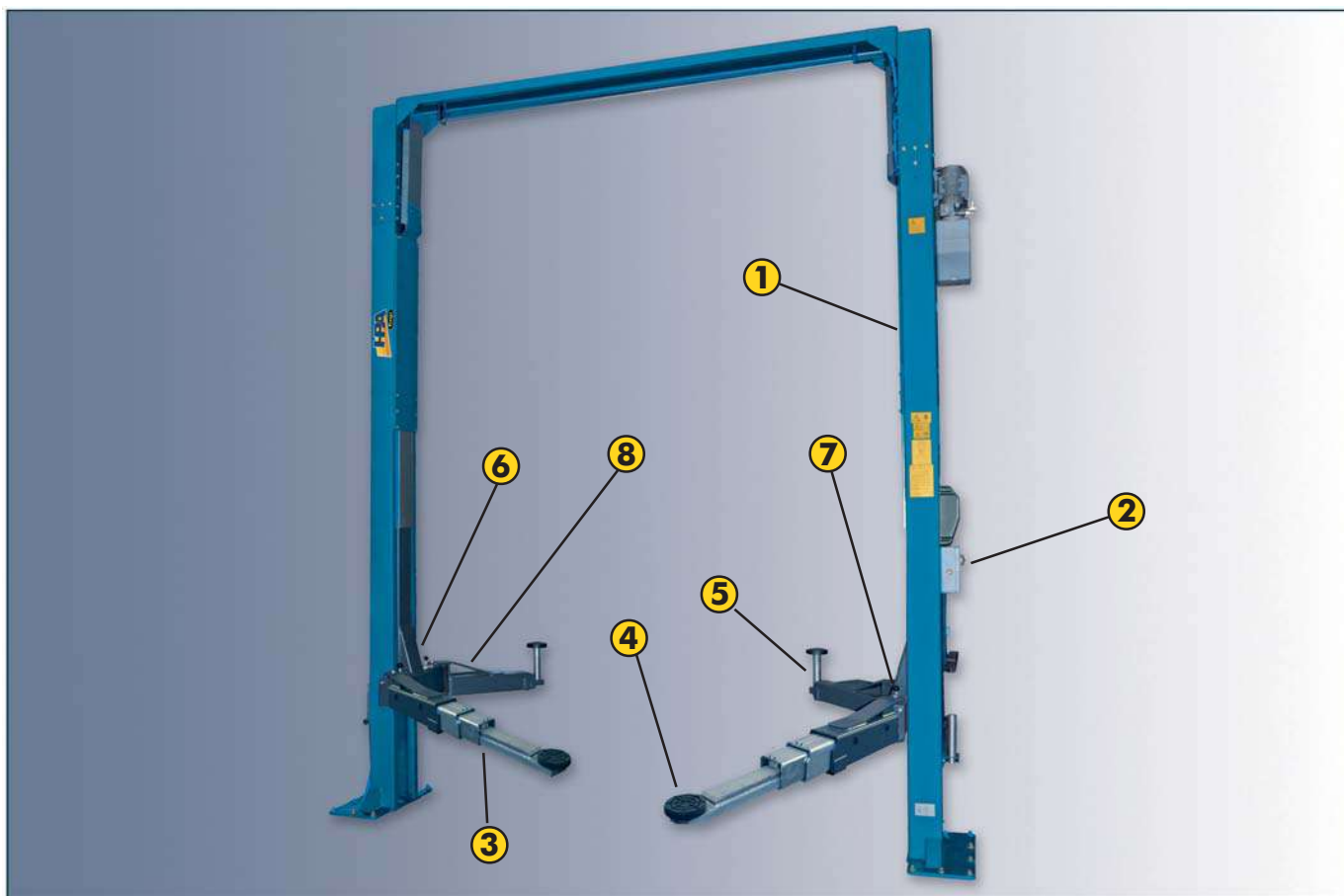

### Caratteristiche generali

Il sollevatore **P2C 255 HTS-XV** è azionato tramite un circuito idraulico del tipo **master/slave** con riallineamento automatico dei due carrelli ad ogni ciclo di sollevamento; grazie a questo circuito il sollevatore è particolarmente affidabile, facile da installare e non necessita di registrazioni meccaniche dopo la prima installazione (non ci sono funi metalliche fra le colonne).

#### Versione extra alta

Progettato con bracci a 4 stadi per permettere il sollevamento di autoveicoli a passo lungo. Specifico per furgoni, fuoristrada e veicoli molto alti in genere.



### Main features

The **P2C 255 HTS-XV** lift is operated by a **master/slave** type hydraulic circuit with automatic realignment of the two carriages at each lifting cycle; thanks to this circuit, the lift is particularly reliable, easy to install and does not require mechanical adjustments after the first installation (there are no metal ropes between the columns).

#### Extra high version

Designed with four-section lifting arms for the lifting of vehicles with extended-wheel base. Suitable for vans, off-road and high-roof vehicles in general.



### Características generales

El elevador **P2C 255 HTS-XV** se acciona mediante un circuito hidráulico de tipo **master/slave** con realineación automática de las dos carretillas en cada ciclo de elevación; gracias a este circuito, el elevador es especialmente fiable, fácil de instalar y no necesita regulaciones mecánicas después de la primera instalación (no hay cables metálicos entre las columnas).

#### Versión extra alta

Diseñado con brazos de 4 etapas para poder elevar vehículos de paso ancho. Específicamente para furgonetas, vehículos todoterreno y camiones muy altos en general.

Bracci simmetrici ribassati a 4 stadi.  
4-section low profile lifting arms.  
Brazos simétricos rebajados de 4 etapas.

P2C 255 HTS-XV

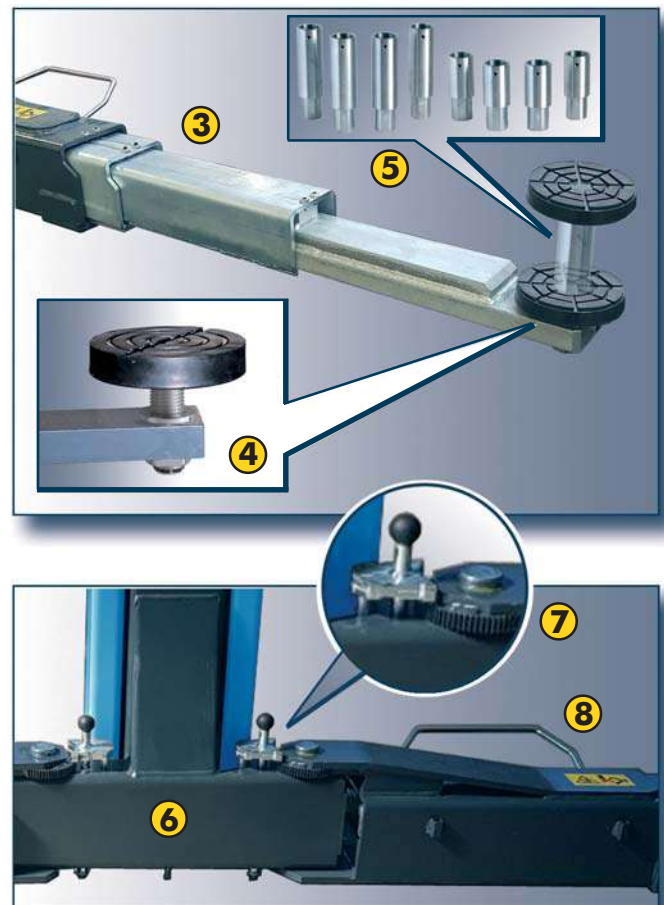
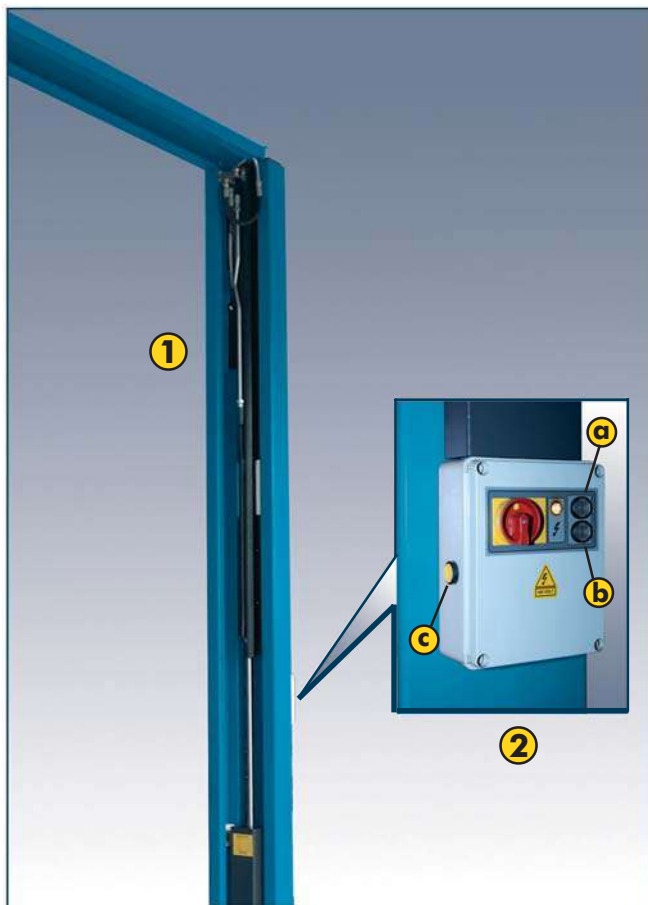

### IT Caratteristiche funzionali

1. Azionamento con **cilindri in trazione** e con circuito master/slave.
2. Gruppo comandi: **a.** pulsante di salita; **b.** pulsante di discesa; **c.** pulsante esclusione stazionamento automatico.
3. 4 bracci di sollevamento simmetrici a **4 stadi**.
4. Tamponi filettati **regolabili** in altezza.
5. Tamponi con distanziatori da 80 e 140 mm (*di serie*) che consentono **tre altezze diverse**.
6. Gruppo carrello attacco bracci, compatto e ad **ingombro ridotto** da terra.
7. Arresto rotazione bracci a **settori dentati**.
8. Sicurezze **salvapiedi** su tutti i bracci di sollevamento.

### EN Functional features

1. Drive with **traction cylinders** and with master/slave circuit.
2. Control unit: **a.** up button; **b.** down button; **c.** automatic braking exclusion button.
3. 4 symmetric **4-section** lifting arms.
4. Threaded pads with **adjustable** height.
5. Pads with 80 and 140 mm spacers (supplied as standard) allow **three different heights**.
6. Arm attachment carriage unit, compact and with **reduced overall dimensions** from the ground.
7. **Toothed sector** arm rotation stop system.
8. **Foot guard** on all lifting arms.

### ES Características funcionales

1. Accionamiento con **cilindros en tracción** y con circuito master/slave.
2. Grupo centralita: **a.** botón de ascenso; **b.** botón de descenso; **c.** botón de exclusión del estacionamiento automático.
3. 4 brazos simétricos **de cuatro extensiones**.
4. Tacos roscados **ajustables** en altura.
5. Tacos con espaciadores de 80 y 140 mm (*suministrados de serie*) que permiten disponer **de tres alturas diferentes**.
6. Grupo carretilla de fijación de brazos, compacto y de **tamaño reducido** del suelo.
7. Parada rotación brazos con **sectores dentados**.
8. Dispositivo de **protección de pies** en todos los brazos.



Dati tecnici	Technical data	Datos técnicos
<input type="checkbox"/> Capacità max. di sollevamento	Load capacity	Capacidad de elevación máxima 5.500 kg
<input type="checkbox"/> Tempo di salita/discesa	Lifting/Lowering time	Tiempo de subida/bajada 45/42 s
<input type="checkbox"/> Potenza motore	Electric motor power	Potencia motor 2,6 kW (400 V - 3 Ph - 50 Hz)
<input type="checkbox"/> Alimentazione	Power supply	Alimentación 230/400 V - 3 Ph - 50/60 Hz
<input type="checkbox"/> Tensione circuito dei comandi	Control circuit voltage	Voltaje circuito de mandos 24 V

Per i dati tecnici d'installazione, caratteristiche del suolo, carichi trasmessi a terra e tipo di ancoraggi, fare riferimento alle tabelle nell'apposita sezione dedicata sul nostro sito internet: [www.simpesfaip.it](http://www.simpesfaip.it).

Accessori a richiesta	Optional accessories	Accesorios bajo pedido
 <p>①</p>	 <p>②</p>	 <p>③</p>

<b>Obbligatori:</b> <input type="checkbox"/> 1. Set tasselli fissaggio al suolo (16 pz.) <b>Raccomandati:</b> <input type="checkbox"/> 2. Pompa manuale di emergenza <input type="checkbox"/> 3. Kit Crafter	<b>Compulsory:</b> Set of masonry screws (16 pcs.) <b>Recommended:</b> Emergency hand pump Crafter kit	<b>Necesarios:</b> Set tacos de fijación (16 pz) <b>Recomendados:</b> Bomba manual bajada de emergencia Kit Crafter
--	--	---

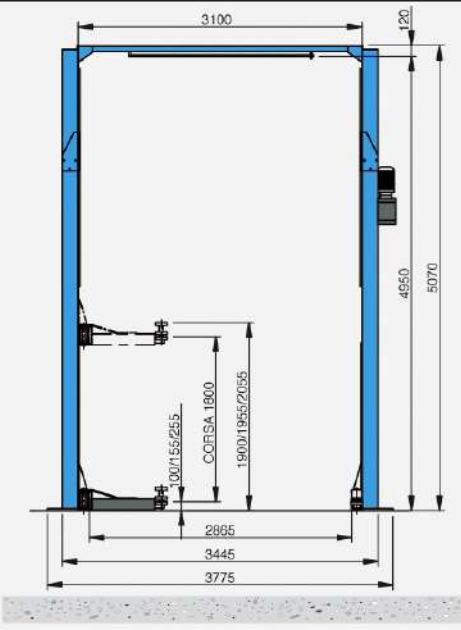
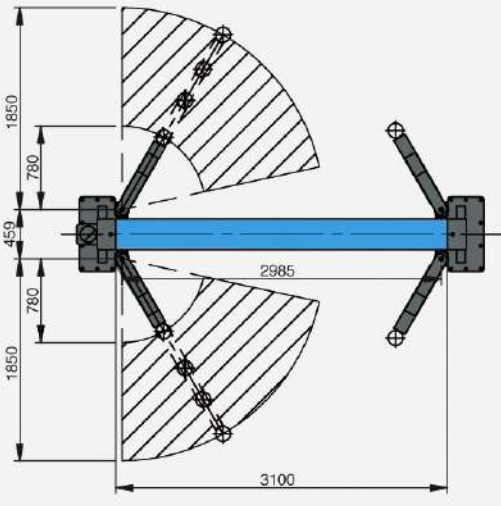
Dimensioni	Dimensions	Dimensiones
		

Le immagini, le configurazioni e le caratteristiche tecniche riportate nel presente stampato hanno il solo scopo di presentare il prodotto e sono soggette a variazioni. Per una corretta definizione dell'ordine fare sempre riferimento al listino prezzi in vigore.  
 The illustrations, configurations and technical features in this publication are intended to present the product only, and are subject to variation.  
 To ensure correct ordering, always refer to the current price list.  
 La única finalidad de todas la imágenes, configuraciones técnicas incluidas en el presente documento es la presentación del producto e, por tanto, están sujetas a variaciones. Para efectuar correctamente un pedido se deberá tomar siempre como referencia la lista de precios válida.



NEXION S.p.A. - Italy - Società unipersonale soggetta a direzione e coordinamento di Minio s.r.l. - A sole shareholder Minio company - [www.hpa-faip.it](http://www.hpa-faip.it) - [info@hpa-faip.it](mailto:info@hpa-faip.it)

