



P2C 232 HB



**Sollevatori elettroidraulici
a due colonne con bracci simmetrici
ribassati a 3 sfili**

**Two-column electro-hydraulic lifts
with 3-section low-profile lifting arms**

**Elevadores electro-idr ulicos de dos
columnas con brazos de 3 etapas**

**P2C 232
HB / HCT / HCS / HCA**

P2C 232 HB / HCT / HCS / HCA

Sollevatori elettroidraulici a 2 colonne con bracci simmetrici ribassati a 3 sfilii.
Two-column electro-hydraulic lifts with 3-section support arms.
Elevadores electro-idráulicos de dos columnas con brazos de 3 etapas.

P2C 232 HCT P2C 232 HCS

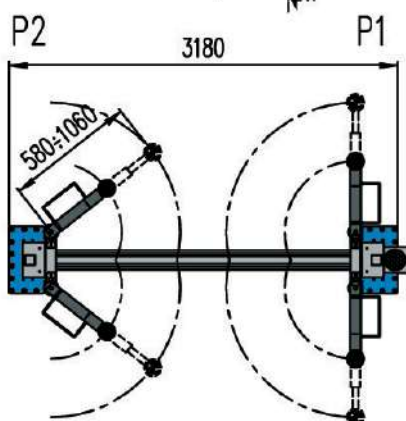
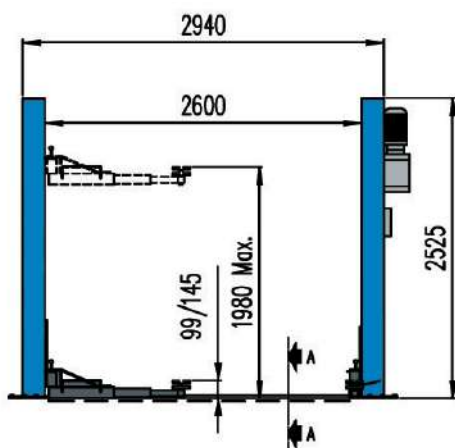

P2C 232 HCT

P2C 232 HCS

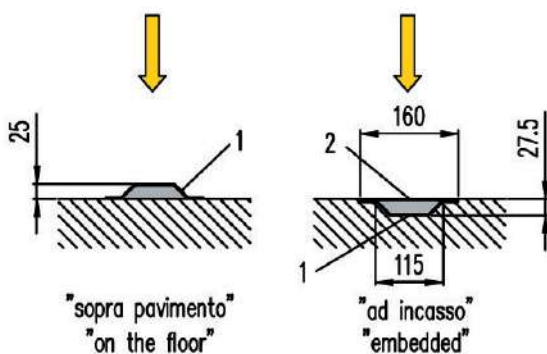

"sopra pavimento"
"on the floor"

"ad incasso"
"embedded"

Sez. A-A - Canalina a pavimento
("sopra pavimento" o "ad incasso")

Sez. A-A - Floor channel
("on the floor" or "embedded")



Caratteristiche generali

A richiesta:

- Serie prolunghe tamponi.
- Pompa manuale di emergenza.



Main features

On request:

- Set of extension pads.
- Emergency hand pump.



Características generales

Opcionales:

- Serie de alargador tampones.
- Bomba manual de emergencia.

Elektrohydraulischen 2-Säulen hebebühnen mit 3-teiligen Teleskop-Armen.
 Ponts élévateurs électro-hydrauliques à deux colonnes avec bras à 3 positions.
 Elevadores electro-idráulicos de duas colunas com braços de 3 fases.

**P2C 232 HB /
 HCT / HCS / HCA**

Hauptmerkmale

Sonderzubehör:

- Set mit Auflagekissen.
- Manuelle Notpumpe.

Caractéristiques générales

Sur demande:

- Série de rallonge tampons.
- Pompe manuelle d'urgence.

Características gerais

Opcionais:

- Conjunto extensão tampão.
- Bomba manual de emergência.

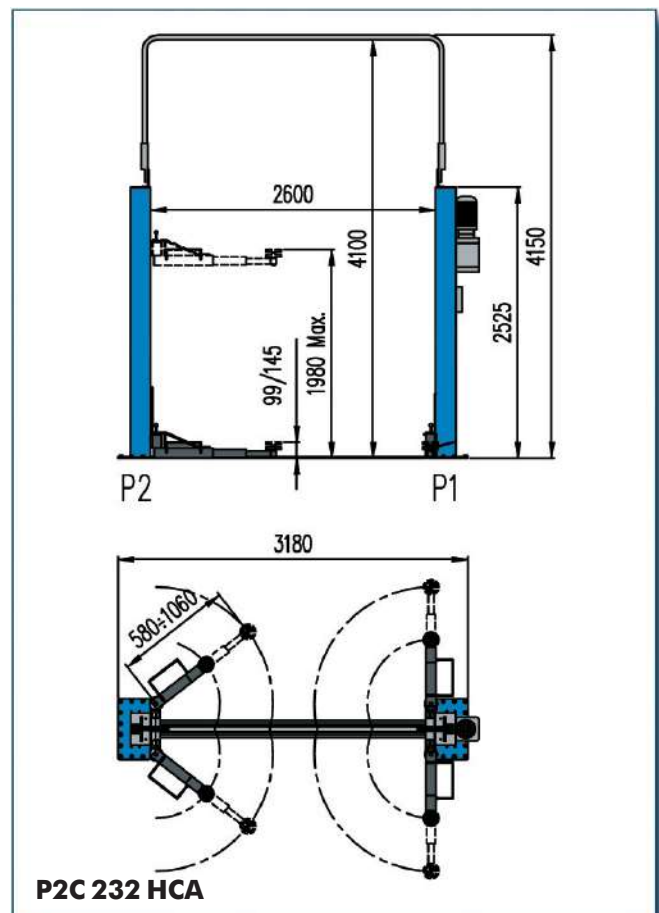
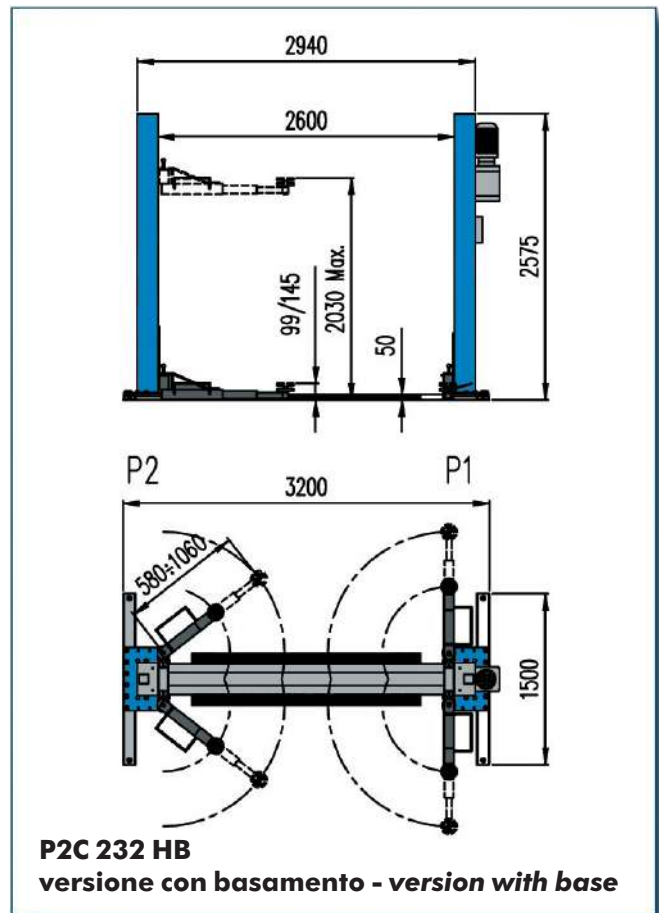

P2C 232 HB / HCT / HCS / HCA

Elektrohydraulischen 2-Säulen hebebühnen mit 3-teiligen Teleskop-Armen.
Ponts élévateurs électro-hydrauliques à deux colonnes avec bras à 3 positions.
Elevadores electro-idráulicos de duas colunas com braços de 3 fases.



Dati tecnici

Technical data

<input type="checkbox"/> Capacità massima di sollevamento	Load capacity	3.200 kg
<input type="checkbox"/> Tempo di salita	Lifting time	30 s
<input type="checkbox"/> Tempo di discesa	Lowering time	34 s
<input type="checkbox"/> Livello di rumorosità in servizio	Noise level when running	< 70 dB (A)
<input type="checkbox"/> Potenza motore (400 V - 3 Ph)	Electric motor power (400 V - 3 Ph)	2,6 kW
<input type="checkbox"/> Tensione circuito dei comandi	Control circuit tension	24 V
<input type="checkbox"/> Alimentazione	Power supply	230/400 V - 3 Ph - 50/60 Hz 230 V - 1 Ph - 50 Hz

Le immagini, le configurazioni e le caratteristiche tecniche riportate nel presente stampato hanno il solo scopo di presentare il prodotto e sono soggette a variazioni.
The illustrations, configurations and technical features in this publication are intended to present the product only, and are subject to variation.

Per i dati tecnici d'installazione, caratteristiche del suolo, carichi trasmessi a terra e tipo di ancoraggi, fare riferimento al manuale d'uso.



Datos técnicos

Technische Daten

<input type="checkbox"/> Capacidad de elevación máxima	Max. Hubkraft	3.200 kg
<input type="checkbox"/> Tiempo de subida	Hubzeit	30 s
<input type="checkbox"/> Tiempo de bajada	Senkzeit	34 s
<input type="checkbox"/> Nivel de ruido en servicio	Geräuschpegel	< 70 dB (A)
<input type="checkbox"/> Potencia motor (400 V - 3 Ph)	Motorleistung (400 V - 3 Ph)	2,6 kW
<input type="checkbox"/> Tensión circuito de mandos	Steuerspannung	24 V
<input type="checkbox"/> Alimentación	Stromversorgung	230/400 V - 3 Ph - 50/60 Hz 230 V - 1 Ph - 50 Hz

La única finalidad de todas la imágenes, configuraciones técnicas incluidas en el presente documento es la presentación del producto e, por tanto, están sujetas a variaciones.
Die Abbildungen, Konfigurationen und technische Merkmale in dieser Veröffentlichung werden beabsichtigt, das Produkt nur zu präsentieren, und unterliegen Veränderungen.



Données techniques

Dados técnicos

<input type="checkbox"/> Capacité de levage max.	Capacidade de elevação máx.	3.200 kg
<input type="checkbox"/> Temps de montée	Tempo de subida	30 s
<input type="checkbox"/> Temps de descente	Tempo de descida	34 s
<input type="checkbox"/> Niveau de bruit en service	Nível de ruído em serviço	< 70 dB (A)
<input type="checkbox"/> Puissance du moteur (400 V - 3 Ph)	Potência do motor (400 V - 3 Ph)	2,6 kW
<input type="checkbox"/> Tension du circuit des commandes	Tensão do circuito dos comandos	24 V
<input type="checkbox"/> Alimentation	Alimentação	230/400 V - 3 Ph - 50/60 Hz 230 V - 1 Ph - 50 Hz

Les images, les configurations et les caractéristiques techniques ne figurent dans le présent imprimé que dans le but de présenter le produit et peuvent subir des variations.
As imagens, configurações e características técnicas indicadas nesta publicação têm apenas a finalidade de apresentação do produto e estão sujeitas a modificações.



NEXION S.p.A. - Italy - Società unipersonale soggetta a
direzione e coordinamento di Minio s.r.l. -
A sole shareholder Minio company -
www.hpa-faip.it - info@hpa-faip.it

